

Installation, operating and
maintenance instructions

ELECTRIC CHIPS SCUTTLE

ISP4





CHARACTERISTICS

Supplied by:

Date:

Customer Service:



FAX

e-mail



INDEX

1 Diagram	4
2 Features of the appliances	5
3 Technical data	5
4 Installation instructions	6
4.1 Safety rules	6
4.2 Structure, framework and safety devices of the appliances	6
4.3 Assembly	6
4.3.1 Installation premises	6
4.3.2 Statutory regulations and technical requirements	6
4.3.3 Installation	6
4.3.4 Wiring	6
4.3.5 Equipotential	6
4.4 Preparing for installation	6
5 Operation preparation	7
5.1 Preparation and Start-up	7
5.1.1 Start-up	7
5.1.2 Operator training	7
5.2 Maintenance	7
5.3 Ignition	11
5.4 Cleaning and taking care of the machine	11
6 Instructions for use	12
6.1 Safety, cleaning and repair rules	12
6.2 Turning the appliance off in case of breakdown	12
6.2.1 What to do in case of failure or prolonged period of disuse	12
6.3 Appliance care and frequency of maintenance	12
6.4 Recommendations for handling stainless steel industrial kitchens	12
6.4.1 Useful information on stainless steel	12
6.4.2 Warnings and advice for maintenance of stainless steel appliances	13
6.4.3 WEEE Directive	13
7 Appendix: Electrical diagrams	14





1 - DIAGRAM

Fig. 1

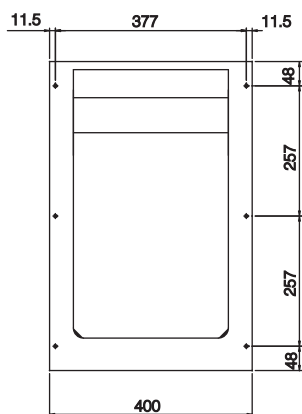
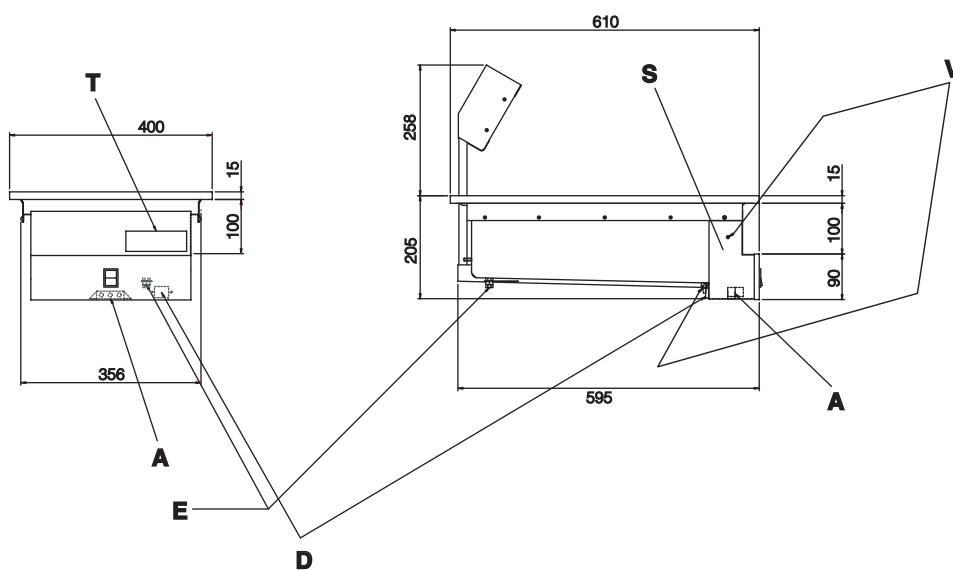
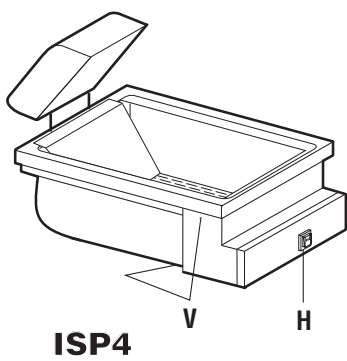

ISP4

- A** Terminal board
- D** Cable input
- E** Equipotential
- H** Switch
- T** Data plate
- V** Screw



2 - CHARACTERISTICS OF THE APPLIANCES

These appliances are used for professional purposes. Installation, repair and use must be carried out by expert personnel.

The data plate (T) is located on the appliance and contains all the data needed for installation.

	CAT/KAT	GAS/GAZ	G30	G31	G20	G25	SE <input type="checkbox"/>	FI <input type="checkbox"/>	DK <input type="checkbox"/>	CZ <input type="checkbox"/>	SK <input type="checkbox"/>	SI <input type="checkbox"/>
	I12H3B/P	P mbar	30	30	20	-	IT <input type="checkbox"/>	CH <input type="checkbox"/>	PT <input type="checkbox"/>			
	I12H3+	P mbar	30	37	20	-	ES <input type="checkbox"/>	IE <input type="checkbox"/>	GB <input type="checkbox"/>	GR <input type="checkbox"/>		
	I12L3B/P	P mbar	28	37	20	-						
	I12L3B+	P mbar	30	30	-	25	NL <input type="checkbox"/>					
	I12ELL3B/P	P mbar	50	50	20	20	DE <input type="checkbox"/>					
	I12E+3+	P mbar	28	37	20	25	FR <input type="checkbox"/>	BE <input type="checkbox"/>				
	I12H3B/P	P mbar	50	50	20	-	AT <input type="checkbox"/>	CH <input type="checkbox"/>				
	I12E	P mbar	-	-	20	-	LU <input type="checkbox"/>					
	I12H3B/P	P mbar	30	30	-	-	EE <input type="checkbox"/>	LV <input type="checkbox"/>	LT <input type="checkbox"/>			
	I12H3+	P mbar	28	37	20	-	EE <input type="checkbox"/>	LV <input type="checkbox"/>	LT <input type="checkbox"/>			
	I13B/P	P mbar	30	30	-	-	NO <input type="checkbox"/>	MT <input type="checkbox"/>	CY <input type="checkbox"/>	IS <input type="checkbox"/>	HU <input type="checkbox"/>	
	I13+	P mbar	28	37	-	-	CY <input type="checkbox"/>					
Predisposto a gas - Gas preset - Prevu pour gaz: Eingestellt für Gas - Preparado para gas - Geschrukt voor:												
V AC	kW		Hz		MADE IN ITALY							
THE APPLIANCE MUST BE CONNECTED IN COMPLIANCE WITH THE LAWS IN FORCE AND INSTALLED IN A WELL-VENTILATED ROOM. READ THE INSTRUCTION MANUALS BEFORE INSTALLING AND USING THE APPLIANCE. THE APPLIANCE MUST BE INSTALLED BY QUALIFIED PERSONNEL.												

3 - TECHNICAL DATA

Model	Dim.: LxWxH (total h)	Voltage rating	Power	Lead wire / Section
ISP4	400 x 610 x 220 (480)	230 V	0.65 kW	3 x 1 mm ²



4 - INSTALLATION INSTRUCTIONS

4.1 Safety rules

- Installation, modifications and maintenance of the appliance must be carried out by authorised personnel in compliance with current safety standards. The manufacturer declines all responsibility for failure to comply with these obligations.
- In compliance with international regulations, when connecting the appliance to the mains power supply, a device with a minimum aperture of 3 mm between contacts must be fitted upstream of the appliance, allowing omnipolar disconnection of the appliance from the mains. Also, a high-sensitivity automatic differential switch must be installed which protects against direct or indirect contact with live electrical parts and against current leakage (maximum current leakage permissible by regulations is 1 mA/kW).
- Compare technical datas on grey stickers to those written on this manual and present power supply.
- Do not bend, crush or damage the cables against sharp corners.
- Lay the cables so as to avoid contact with extremely hot surfaces.
- Connection to the grid must be carried out with at least a cable type NYM or H07RN-F.
- The cable - which is totally sheathed - must be led inside the appliance through the cable clamp and cable raceway installed on the appliance.
- Ventilation system installation can be carried out only by expert personnel.
- If the appliance is to be installed near walls, dividing walls, kitchen equipment or decorative panelling, these should be in non-inflammable material. If not, all appliances must be coated with thermal-insulation fireproof material. Make sure that all fire prevention standards and safety precautions are strictly adhered to.

4.2 Structure, equipment and safety devices of the unit

18/10 chrome-nickel steel outer panelling.

Controls include a green switch.

4.3 Assembly

4.3.1 Installation premises

The appliance should be installed in a well-ventilated room, and if possible under a range hood (check current regulations).

The appliance can be installed on its own or with other similar equipment.

If the appliance is to be installed near inflammable walls, a minimum distance of 150 mm around the sides and back should be allowed.

If this distance cannot be obtained, take proper heat-protection action such as fitting tiles or thermal radiation protection material to the walls.

4.3.2 Statutory regulations and technical requirements

During installation of the appliance, the following regulations must be adhered to:

- Relevant legal directives;
- Local building and combustion regulations;
- "Technical rules for gas systems" worksheet;
- "Technical rules for liquid gas" worksheet;
- "Gas installations in industrial kitchens" worksheet;
- Relative accident prevention standards;
- Local gas utility regulations.
- Local building and fire codes.

4.3.3 Installation

Installation, start-up and maintenance should only be carried out by expert personnel.

All work required to install the appliance should be carried out in compliance with all local standards and regulations.

The manufacturers decline all responsibility where poor performance is due to incorrect installation in disregard of the above conditions.

4.3.4 Wiring

Before to drop in the unit on the top, fix input cable. Electric connections must be executed by qualified technician respecting rules and regulations in force. Remove the protection terminal board/wiring S (fig. 1) unscrewing screws and nut at sight V (fig. 1), pass the cable through the chock-cablepress D (fig. 1) and connect wire to corresponding terminal of the terminal board A (fig. 1), screw again.

When choosing the lead wire, make sure it has the following characteristics: it should be at least of the H07 RN-F type and its section should be large enough for the appliance (see "Technical data").

Wire input is on the back wall.

The terminal board is at the front, behind the control panel.

The ground wire must be long enough to prevent tug after the cable lead wires in case of raceway breakage.

 In compliance with international regulations, when connecting the appliance to the mains power supply, a device with a minimum aperture of 3 mm between contacts must be fitted upstream of the appliance, allowing omnipolar disconnection of the appliance from the mains. Power switches, relays and fuses are considered suitable separation devices.

4.3.5 Equipotential

The appliance must be hooked up to a unipotential system. The connection screw E (fig. 1) is located at the bottom, back side.

It is labeled with the symbol .

 The manufacturers cannot be held responsible for any damage due to inadequate or incorrect installation. Under such circumstances the guarantee will be considered null and void.

4.4 Preparing for installation

The electric chips scuttle type INCASSO must be set on a regular worktable, made of fireproof material and in compliance with the current hygiene and safety standards.

It is of vital importance to observe the following instructions.

Chips scuttle units can go near other appliances such as a fryer, as long as the required distance of 50 mm (min.) is kept.

In order to install the unit properly on the worktable, proceed as follows:

A: fig. 2) Base: With a drill, make an opening in the worktable as



4 - INSTALLATION INSTRUCTIONS

described in fig. 2.

The worktable and appliance are clamped with six M5 screws; first drill the relevant holes in the worktable as described in fig. 2. In order to prevent liquids from leaking in between the lining and the appliance, it is necessary to waterproof the leaks with sanitary silicone, anti-mould and heat resistant to at least 100°C (i.e. Pactan 6076). The knob position is fixed; therefore, in the design of the parts where the appliance will be fit into, the relevant panel will have to be provided with a special hole (fig. 1).

B: fig. 3) Housing: Make an opening in the worktable in order to fit in the appliance as described in fig. 3 (the rise can be performed perfectly by means of a bent L-shaped metal support). The appliance is clamped to the worktable with six M5 screws fit through holes previously drilled (fig. 3). Fit the appliance and fasten it to the worktable with the screws. Fill the intermediate leak (about 3 mm wide) with heat resistant (at least 100°C) anti-mould silicone (i.e. Pactan 6067) according to the current hygiene standards. The knob position is fixed, hence the furniture structure where the appliance has to be housed will have to be provided with matching holes (fig. 1).

C: fig. 4) Base with anti-seepage edge: Make a frame on the stainless steel worktable as described in fig. 4. Fit the appliance and fasten it with the parts supplied with it. The knob position is fixed; hence the worktable structure will have to be provided with matching holes (fig. 1).

In order to prevent overheating of the furniture, it is important to have air circulate inside the space near the machines. If the space under the machine housing is accessible, a closing panel must be put in to prevent accidental contact with hot walls and electric wires. To this end, it is necessary to make holes at the back and possibly at the front as well, for a total of at least 40 cm² for the models 400. This panel must be made of fireproof material and applied at a distance between 50 mm (min.) and 90 mm (max) from the bottom of the machine, further, to ensure internal air circulation must be provided with a hole 40 cm². Preferably at the front (fig. 2/3/4).

Panels and/or inflammable parts must be at a distance of at least 300 mm from the hot walls of the machine.

Before installing the machines on the furniture, please read the instructions in the "Wiring" section.



5 - SET-UP FOR OPERATION

5.1 Preparation and Start-up

Before starting up the appliance, remove the protective wrapping. Then carefully clean the working surface and the external parts with lukewarm water and detergent, using a damp rag to remove all traces of anti-rust material applied in the factory, then dry with a clean cloth.

5.1.1 Start-up

Before using the appliance for the first time, thoroughly clean out the vessel (see paragraph entitled "Cleaning and taking care of the machine").

Check that the appliance is connected up properly and start according to instructions overleaf.

5.1.2 Operator training

- Explain and show the user how the machine works according to the instructions, and hand him this manual.
- Remind the user that any structural alterations or any building modification or renovation may affect the combustion air supply, thus requiring a second operation check.

5.2 Maintenance



Attention! Before doing any repair or maintenance work, unplug the appliance.



CHARACTERISTICS

Fig. 2

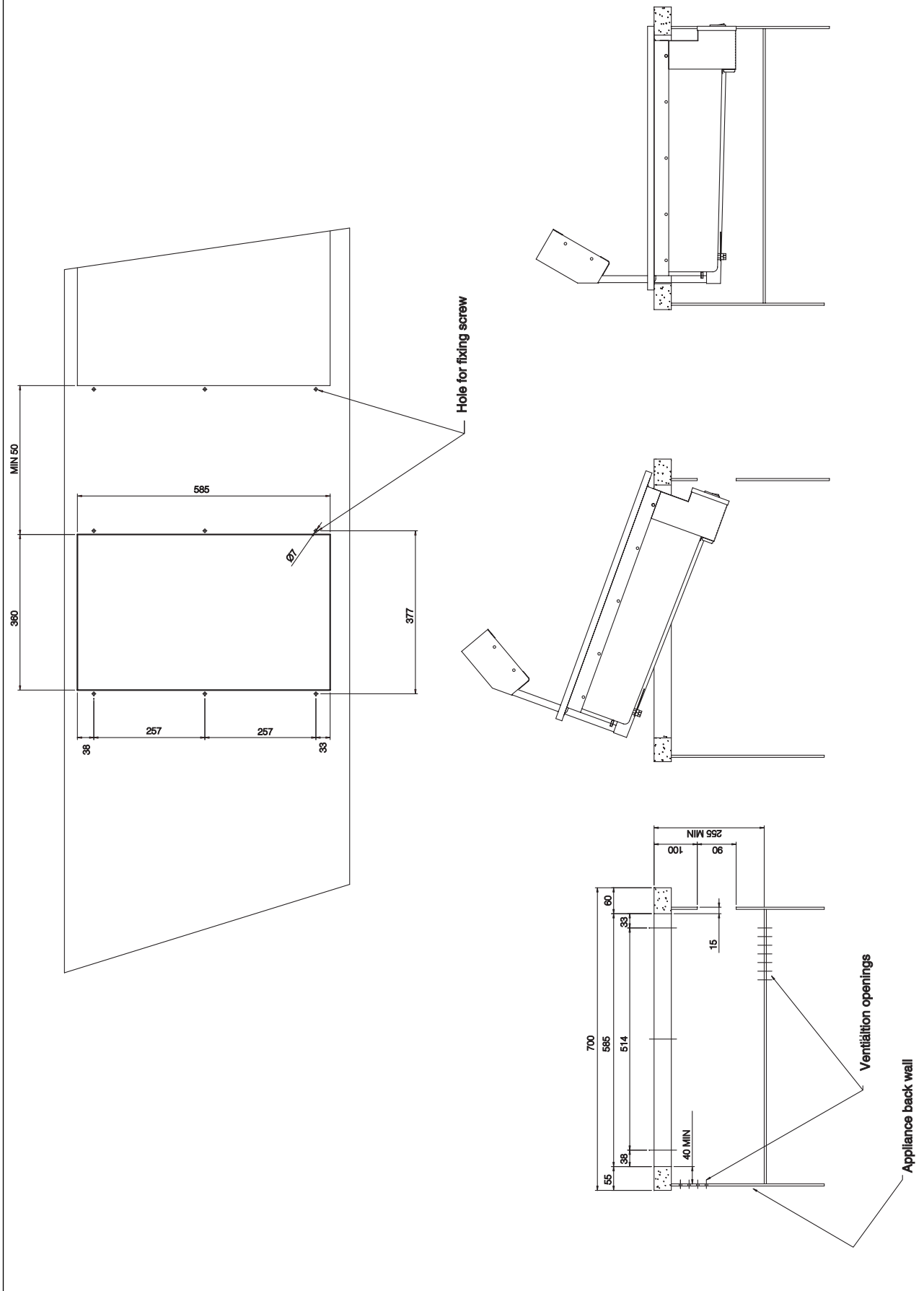



CHARACTERISTICS

Fig. 3

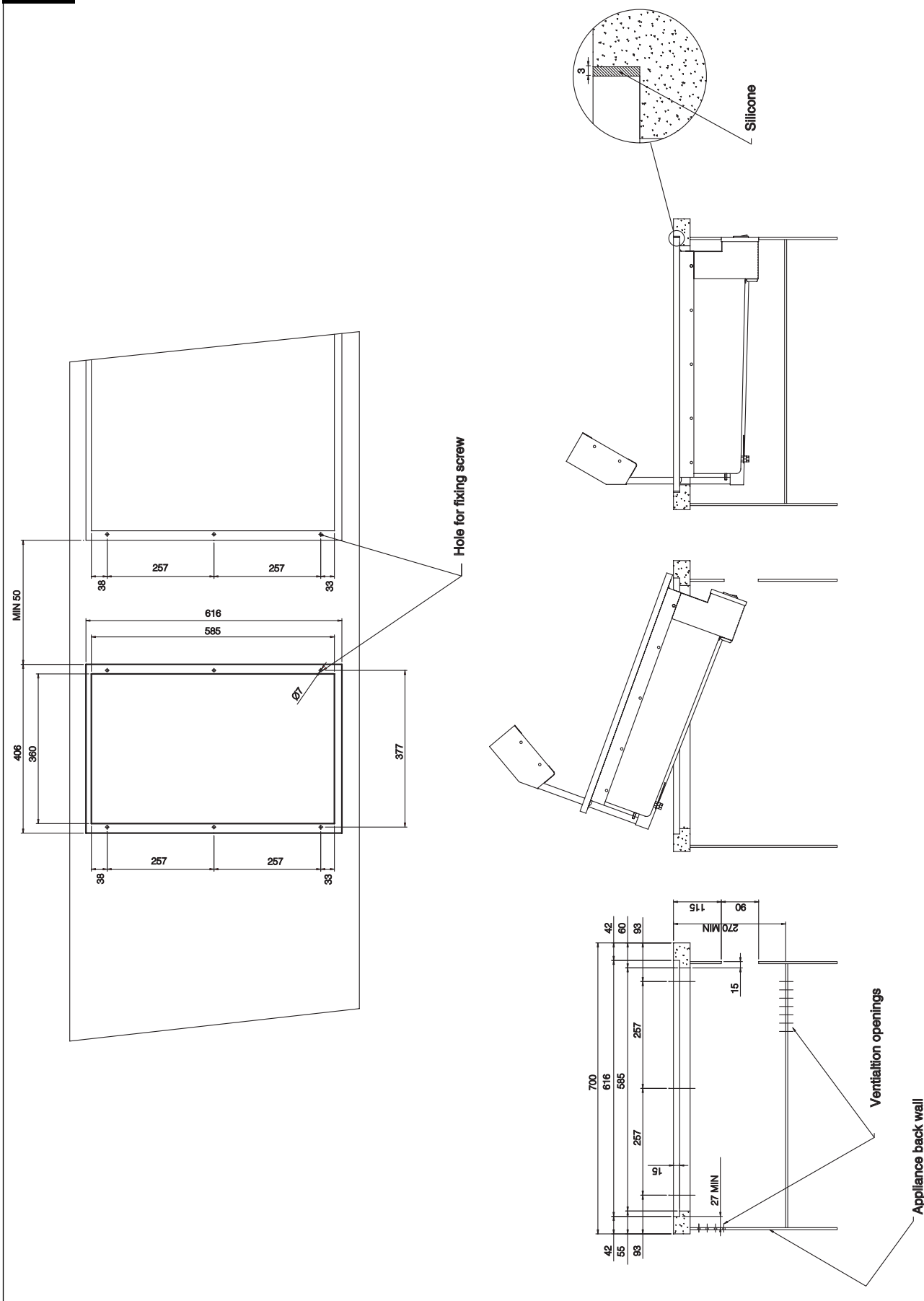



CHARACTERISTICS

Fig. 4

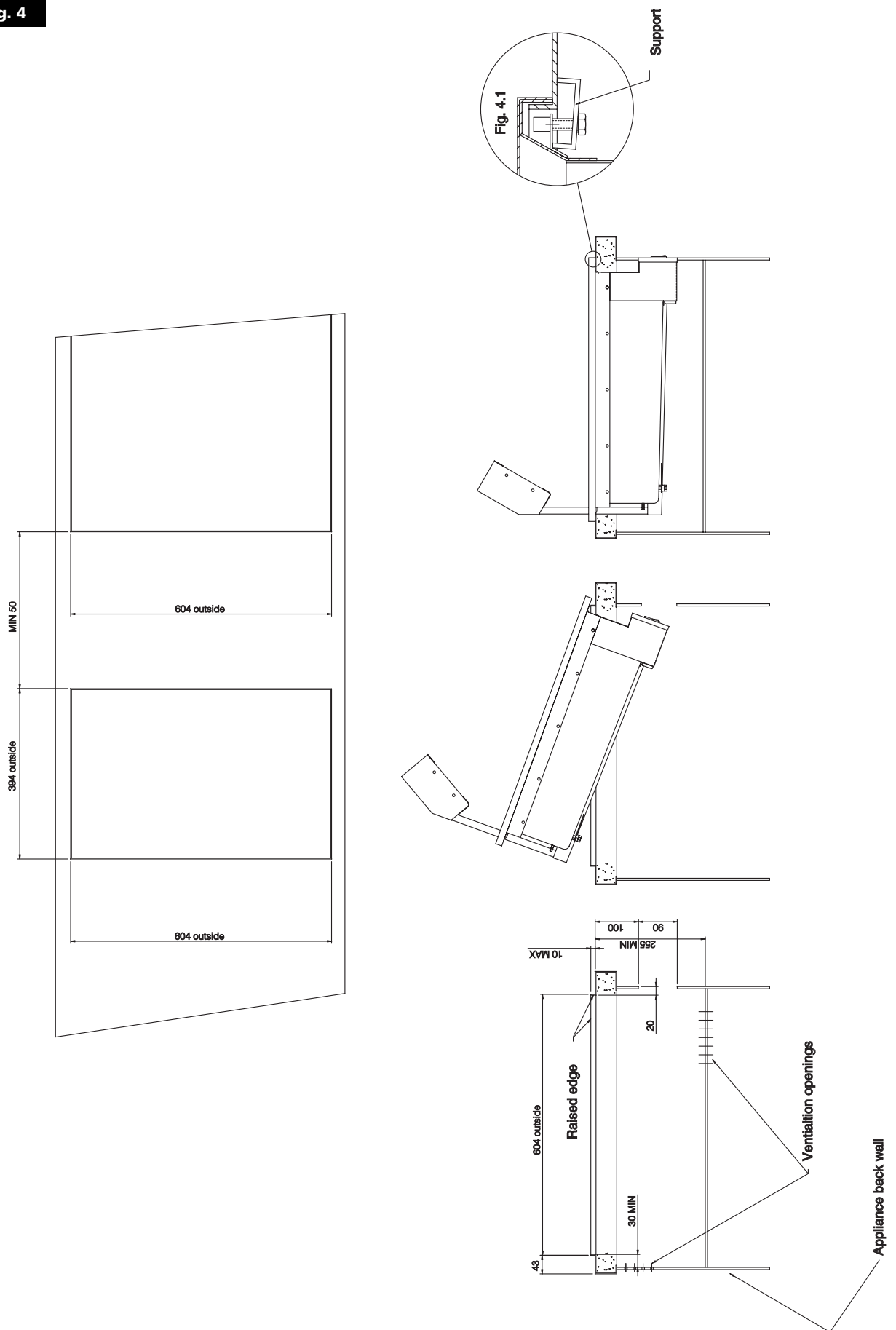



5 - SET-UP FOR OPERATION

5.3 Ignition



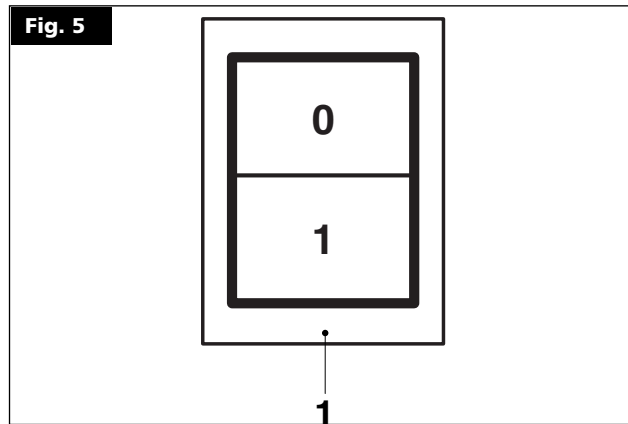

Turn on the main switch upstream of the appliance.

Turn on switch (pos. 1 fig. 5) of the appliance, come on shows that the appliance is on.

To turn the appliance off, turn off switch.

















5.4 Cleaning and taking care of the machine

-  Never clean the appliance with jets of water, whether direct or pressurised!
-  Never clean the appliance before it has cooled down.
-  Rinse the surface with clean water and a soft cloth to get rid of all traces of detergent.
-  When finished using the appliance, it should be cleaned thoroughly every evening. Cleaning the appliance daily guarantees perfect long-term operation.
-  Before starting to clean the appliance, disconnect from the mains. The surfaces and steel parts should be washed in warm water using a neutral detergent. Avoid using abrasive or corrosive detergents which could damage the steel.



6 - INSTRUCTIONS FOR USE

6.1 Safety, cleaning and repair rules

-  • This appliance is used for the preparation of meals at industrial level. Usage and cleaning can be carried only by expert personnel. Maintenance and repair can be carried out only by skilled technical personnel.
 -  • These indications must be communicated to all those concerned during internal training.
 -  • Attention! This appliance must be constantly watched over when being used!
 -  • Grease and overheated oil can catch fire. Use this appliance only under constant control. Never use water to put out grease or oil! Cover with a lid, turn off the hot plate and remove pot from the burner.
 -  • Do not leave the burners running.
 -  • Do not overload the kitchen. For proper use, pots should not be bigger than the flames.
 -  • Parts of the appliance and attachments exposed to food must be cleaned with detergents and rinsed thoroughly with potable water.
 -  • Do not clean the appliance using water jets or steam, whether direct or pressurized!
 -  • If the room is being cleaned with water/steam jets or high-pressure equipment, it is necessary to switch off the appliance first!
 -  • Before starting to clean the appliance, disconnect from the mains.
 -  • Do not use inflammable liquid to clean the appliance.
 -  • Repairs may be carried out only by skilled personnel.
 -  • During repairs, the appliance must undergo voltage omnipolar insulation (local switch, i.e. safety load cut-off switch).
 -  • Noise emission values of the appliance in operation are below 70dB (A). This value is compulsory according to certain national safety standards.
- WARNING**
-  **Attention!** The manufacturer declines all responsibility concerning mistakes included in these instructions due to translating or printing errors: the manufacturer also reserves the right to change the product as he sees fit, though without changing its essential features. The manufacturer declines all responsibility for any non-compliance with the provisions contained in this manual.

6.2 Turning the appliance off in case of breakdown

In case of breakdown, shut down the appliance as instructed in the paragraph "What to do in case of failure or prolonged period of disuse". In case of breakdown, close the connecting cock of the unit. Disconnect the appliance from the power mains.

6.2.1 What to do in case of failure or prolonged period of disuse

When the appliance is not to be used for a long time, clean thoroughly, close the gas cock and switch off any electric power.

In case of malfunctioning or failure, close the gas cock. In case of malfunction, call the service centre.

6.3 Appliance care and frequency of maintenance

-  **Attention! When cleaning, carefully avoid washing the appliance with direct water jets or high-pressure water!**

Cleaning must be performed when the appliance is cold.

Thorough daily cleaning of the appliance, after disconnecting it, will keep it in perfect working order and make it last longer. All steel parts should be cleaned with water and a detergent, using a damp cloth; do not use abrasive substances or corroding detergents.

Do not use steel wool, which could cause rust to form.

For the same reason, avoid touching the appliance with anything made of iron. Do not clean with sandpaper and lubricating gel paper.

If absolutely necessary, you may use pumice powder.

If the appliance is extremely dirty, use a synthetic sponge (i.e. Scotchbrite sponge).

After cleaning the appliance, rinse with clean water and wipe with a clean cloth.

If the main burner needs cleaning, proceed as follows:

- Remove the pan support, cover, rings and burner crown;
- Clean burner parts with water, soap and a suitable tool, then rinse and wipe;
- When reassembling the parts, make sure you place them back in the right position.

All maintenance and repair work must be carried out by authorized technicians only.

-  **Never clean the appliance with water jets or high-pressure water!**

The appliance must be checked at least once a year. For this reason, a service agreement contract is recommended.

6.4 Recommendations for the treatment of stainless steel industrial kitchens

6.4.1 Useful information on stainless steel

Industrial kitchens are generally made of stainless steel having the following material codes:

- 1.4016 or 1.4511 = magnetizable chromed steels
- 1.4301, 1.4401 and 1.4571 = non-magnetizable chromed steels

Chromed steels have favourable thermo-technical characteristics. In fact, they have less of a tendency to warp due to the effect of heat.

Chrome-nickel steels, instead, have good corrosion resistance features.

Stainless steel corrosion resistance is given by an inactive coat that builds up on the surface by coming into contact with oxygen.

The oxygen in the air is already enough to build up the inactive coat that allows automatic removal of anomalies and damage due to mechanical actions. The inactive coat builds up or re-builds up faster if the steel comes in contact with running water containing oxygen.

A more powerful effect is given by oxidative acids (nitric acid, oxalic acid). These acids are used if the steel has undergone strong chemical stresses, hence generally losing its inactive coat.

The inactive layer can be chemically damaged or jeopardized by reducing agents (oxygen consumption) if they come in contact with the steel, concentrated or at high temperatures. These active substances include for instance:

- saline and sulphurous substances
- chlorides (salts)
- concentrated spices such as mustard, vinegar essences, soup cubes, kitchen salt solutions, etc.

More damage can be caused by:

- outside rust (i.e. from other components, tools or incipient rust)
- iron particles (i.e. file dust)



6 - INSTRUCTIONS FOR USE

- contact with non-ferrous metals (element build up)
- lack of oxygen (i.e. no air inlet, water lacking oxygen).

6.4.2 Warnings and advice for maintenance of stainless steel appliances

- Stainless steel equipment surfaces must be kept clean and in contact with air at all times. When not running, keep appliance doors open so as to allow air to run through it.
- Regularly remove calcium, grease, starch, and egg white deposits where rust may build up if there is lack of air. Do not use bleaching products or products containing chloride. Follow all indications given by the company concerning special soaps and cleaning methods to be used for the appliance. If no specific cleaning recommendations are available, it is necessary, however, to use detergents having a low chloride content. After cleaning, remove all soap residues with plenty of clean water and thoroughly dry the surfaces.
- Minimize contact of stainless steel with concentrated acids, spices, salts, etc. Even acid vapours coming from cleaning the tiles favour stainless steel corrosion.
- Particularly for pots and multiple appliances, it is not recommended to load the cooking chamber only with food having a high salt content.
It is preferable to cook different food together, i.e. fatty dishes or vegetables containing acids.
- Avoid damaging the stainless steel surface, in particular with different metals. Residues from other metals help build up the formation of chemical microelements that may cause rust. At any rate, it is appropriate to avoid contact between iron and steel since it produces rust. Any contact between stainless steel and iron (steel wool, pipeline chips, chalybeate waters) can start corrosion phenomena.

As for mechanical cleaning, it is recommended to use only steel wool or natural, plastic or steel bristle brushes. Steel wool or brushes with stainless steel can cause rust due to rubbing. Newly formed rust spots can be removed with slightly abrasive liquid soaps or fine-grained sand paper. Larger rust spots can be removed with 2-3% of hot oxalic acid solution. If these cleaning products do not do the job, a nitric acid (10%) treatment is required.

 **Attention! These treatments can be carried out only by expert personnel according to current regulations.**

6.4.3 The 2002/96/EC (WEEE) Directive: information to users

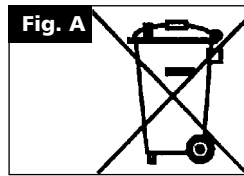

This informational note is meant only for owners of equipment marked with the symbol shown in fig. A on the adhesive label featuring the technical specifications applied on the actual product (the label also giving the serial number).

This symbol indicates that the product is classified, according to the regulations in force, as an item of electrical and electronic equipment and conforms to EU Directive 2002/96/EC (WEEE) meaning that, at the end of its service life, it must be treated separately from domestic waste, i.e. it must be handed in free of charge to a separate waste electrical and electronic equipment collection centre or returned to the reseller when buying a new equivalent item of equipment.

The user is responsible for delivering the unit at the end of its life to the appropriate collection facilities. Failure to do so shall result in the user being subject to the penalties prescribed by the legislation in force on waste.

Suitable separated collection so that the unit no longer used can be sent off for environmentally compatible recycling, treatment and disposal helps avoid possible negative effects on the environment and on health and facilitates the recycling of the product's component materials.

For more detailed information on available collection systems, contact the local waste disposal service or the shop you purchased the unit from.

Producers and importers fulfil their responsibility for environmentally compatible recycling, treatment and disposal both directly and by joining a collective scheme.



7 - APPENDICE: SCHEMI ELETTRICI

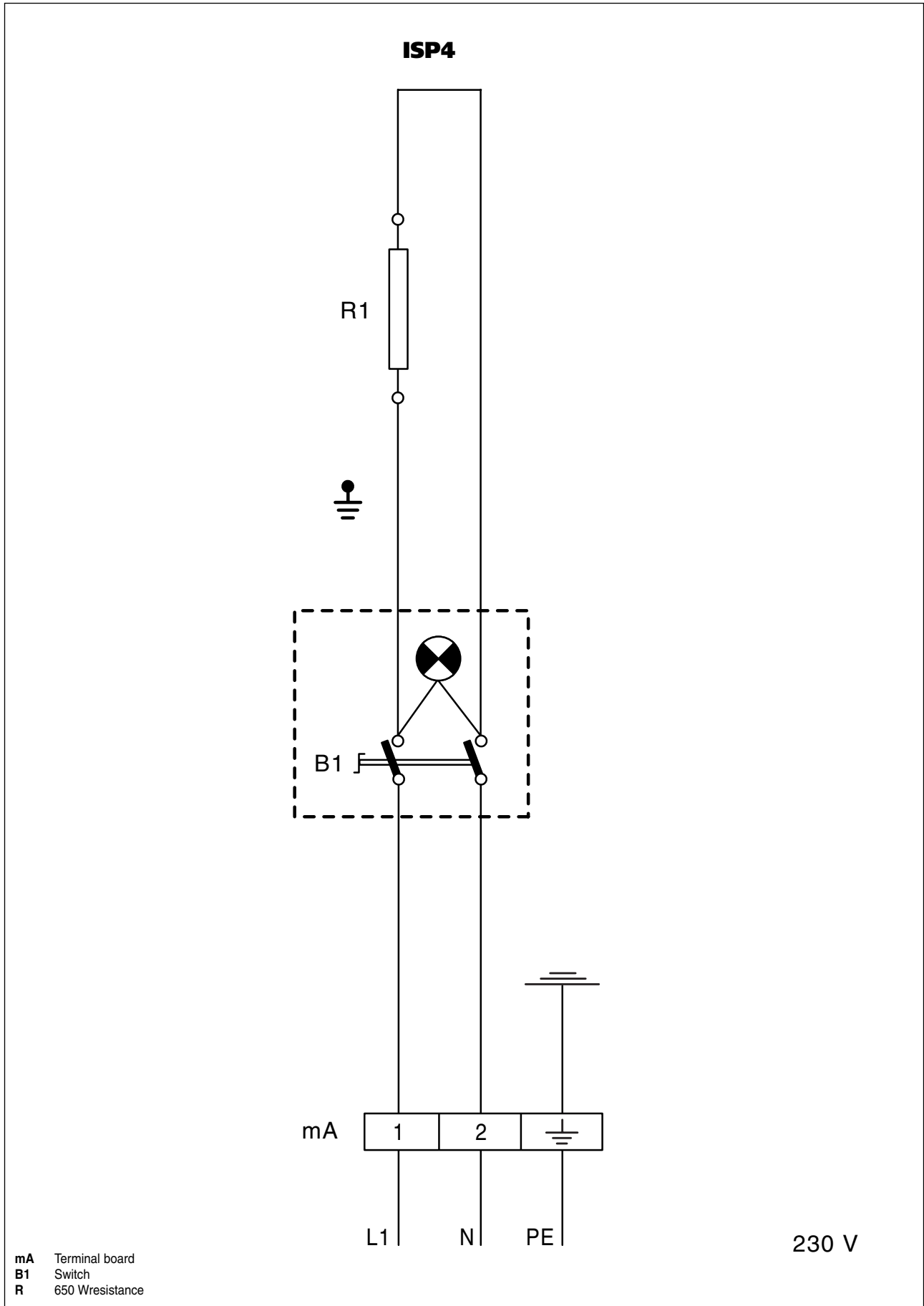

WARNING
THE MANUFACTURER CANNOT BE HELD RESPONSIBLE
FOR ANY INACCURACIES IN THIS BOOKLET DUE
TO COPYING OR PRINTING ERRORS.
DUE TO ITS POLICY OF CONTINUAL PRODUCT IMPROVEMENT,
THE MANUFACTURER RESERVES THE RIGHT
TO MAKE ANY CHANGES DEEMED NECESSARY.
**THE MANUFACTURER CANNOT BE HELD RESPONSIBLE
IF THE INSTRUCTIONS CONTAINED IN THIS MANUAL
ARE NOT OBSERVED.**



GIGA GRANDI CUCINE S.r.l. - Via Pisana, 336 - Loc. Olmo - 50018 SCANDICCI (FI) - ITALY -
Tel. +39 055 722 33 (11 linee r.a.) - Fax +39 055 7310 056 - www.gigagrandicucine.it -
info@gigagrandidicucine.it